

Micro-CT Contrast Scale

QRM-MicroCT-CS

A phantom for evaluating high contrast materials in Micro-CT. Materials of highest interest in small-animal imaging (CaHA and Iodine).

The contrast scale factor allows evaluating the contrast, measured in Hounsfield Units, obtained for a given concentration of a substance, specified in mg/cm^3 . The QRM-MicroCT-ContrastScale phantom provides HA (calcium hydroxyapatite) and iodine samples, i.e. the substances of highest interest in small-animal imaging.

The standard phantoms are scaled down from the diameter of an average human trunk (32 cm) to that of a fat mouse or lean rat (32 mm). Other dimensions as well as inserts with concentrations other than specified here can be produced upon request.

Specifications

Base material resin
Iodine insert $\sim 9 \text{ mg} / \text{cm}^3$
CaHA insert $\sim 1200 \text{ mg HA} / \text{cm}^3$
(actual values can be found on the phantom)

Dimensions for mouse-size phantom:

Diameter 32 mm
Length 40 mm
Weight 35 g
Diameter of inserts 5 mm

References:

- [1] Kalender, W., Durkee, B., Langner, O., Stepina, E., Karolczak, M.: Comparative Evaluation: Acceptance Testing and Constancy Testing for Micro-CT Scanners. Biomedizinische Technik 50 (2005), 1192-1193



Micro-CT Contrast Scale Phantom.

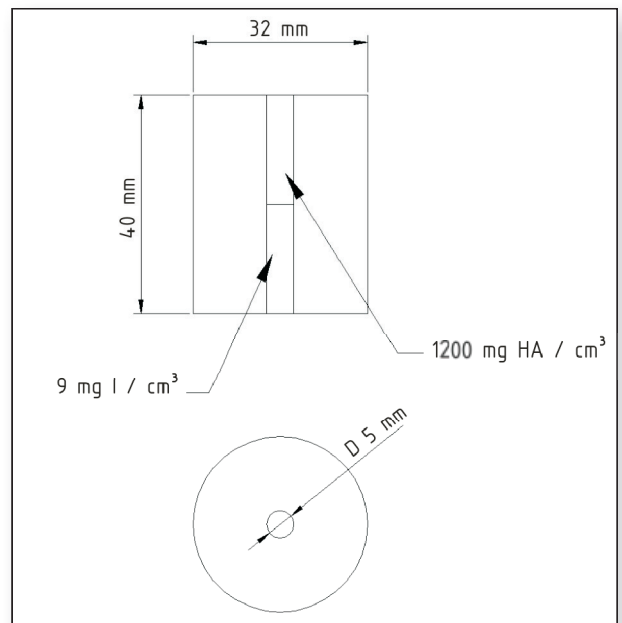

Dimensions and content of the phantom.

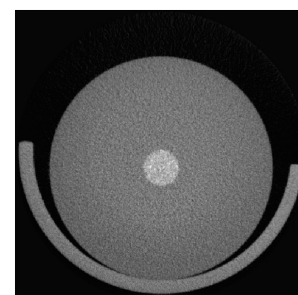

X-ray of the Iodine insert.