

Micro-CT Water Phantom

The QRM MicroCT-Water Phantom can be used for measuring noise and homogeneity. It can easily and bubble free filled with distilled water due to its optimized design providing an extra 'air' cavity.

The QRM-MicroCT-Water Phantom is a hollow cylinder to be filled with distilled water.

It offers an intake/outlet screw in a convex closure head such that it can be used in a rotating gantry or in upright position.

The phantom provides a small cavity in the upper part detaining air bubbles if used in a horizontal position.

The phantom is made of a stable transparent plastic providing a low density (1.0 g/cm³). The transparent wall allows to easily detect air bubbles in the water.

Specifications

Base material rugged transparent plastic
 Wall thickness 0.4 mm
 Diameter 20, 32, 60 mm
 or upon request
 Length 66 or 120 mm
 Inner length 44 or 98 mm
 Weight 20 - 60 g

References:

- [1] Kalender, W., Durkee, B., Langner, O., Stepina, E., Karolczak, M.: Comparative Evaluation: Acceptance Testing and Constancy Testing for Micro-CT Scanners. Biomedizinische Technik 50 (2005), 1192-1193



Standard versions (Ø 20, 32 and 60 mm)
of the QRM Micro-CT Water Phantom

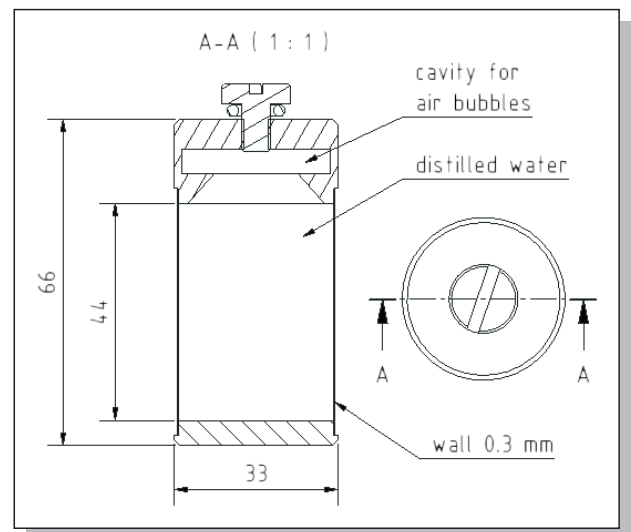

General design of the phantom (32 mm version)

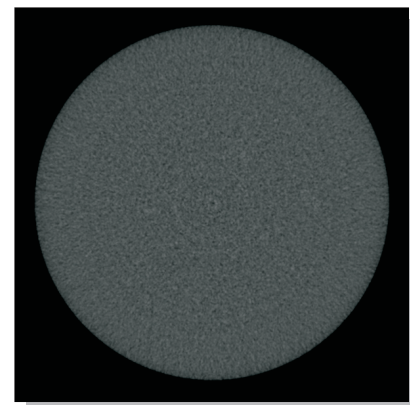

Measuring noise and homogeneity